

Diesel Fuel Hydrometer Set

Assembly and Usage Instructions

- 1) Gently insert the *hydrometer* into the *glass barrel* as shown in **Figure 1**. GENTLY!!
- 2) Lubricate the *rubber stopper* and the top of the *glass barrel* with water. Insert the narrow end of the *rubber stopper* snugly into the top of the *glass barrel*.
- 3) Lubricate the top end of the *glass barrel* and the opening of the *rubber bulb* with water. While holding the *rubber bulb* in one hand, and the *glass barrel* in the other, place the edge of the *glass barrel* into the opening of the *rubber bulb*. Rotate and push the *glass barrel* into the *rubber bulb* until it seats securely into the groove of the *rubber bulb*.
- 4) Lubricate the bottom of the *glass barrel* and the plug side of the *rubber tip* with water. Holding the *glass barrel* in one hand and the *rubber tip* in the other, rotate and push the *rubber tip* into the *glass barrel* until it snaps securely in place.
- 5) You are now ready to use this instrument.

Liquid Extraction

- 1) Always use eye protection when using this instrument.
- 2) Hold assembled tool in the vertical position.
- 3) Gently squeeze *rubber bulb* until most air has been expelled.
- 4) Carefully lower the end of the *rubber tip* into the liquid being tested.
- 5) Release pressure on the *rubber bulb* and allow the liquid to fill the *glass barrel*.
- 6) Lock the *hose clamp* located on the *rubber tip*. It is important to lock the *hose clip* BEFORE the *rubber tip* has been removed from the liquid. If the *rubber tip* is removed before the *hose clip* has been locked, air bubbles will enter the *glass barrel* and affect your reading.
- 7) Hold the instrument vertically, and make sure the hydrometer floats freely in the *glass barrel*.

Instrument Reading

- 1) It is important to become familiar with the *hydrometer* and *thermometer* scale. Refer to **Figure 2** and **3** as a reference.
- 2) Take and record your *hydrometer reading*. Refer to **Figure 4** for proper technique.
- 3) Take and record your *thermometer correction reading* which is located on the right-hand side of the *thermometer* scale.
- 4) Add/Subtract correction reading from *hydrometer reading*.
- 5) This reading is the “*true corrected hydrometer reading*.”

Diesel Fuel Hydrometer Set

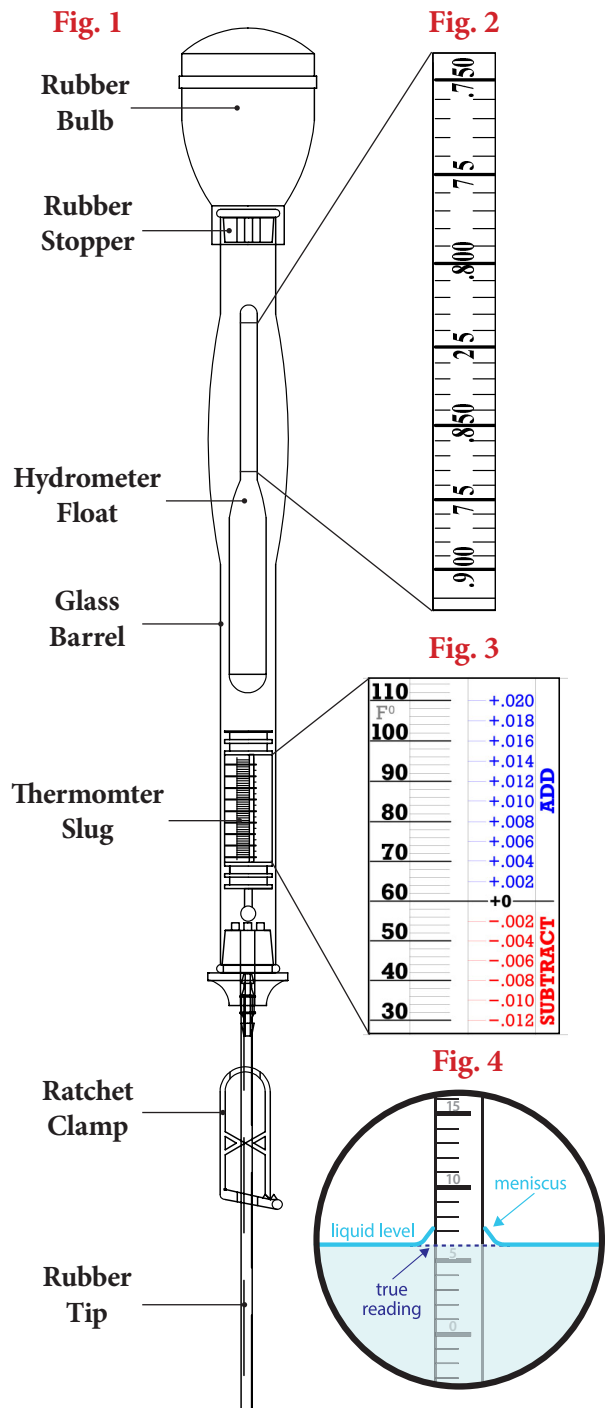

(717) 453-7171 • www.BradyInstruments.com
HANDCRAFTED IN THE U.S.A.